

# PRODUCT DATA SHEET

VERSION 1

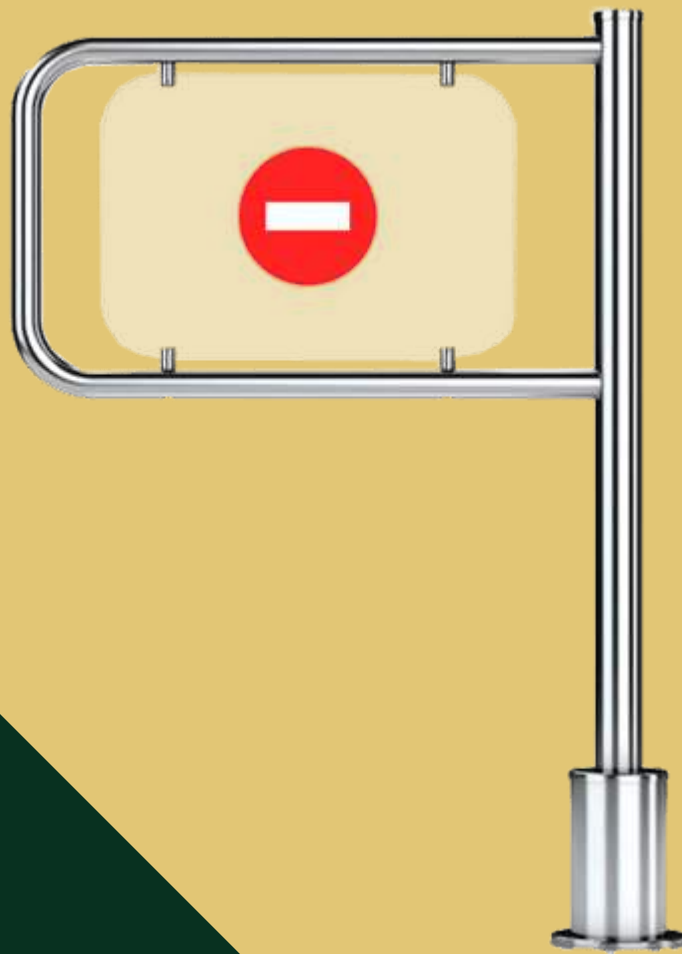

## UKT-110 Single Direction Bolt Down Swing Gate

The UKT-110 manual swing gate offers an extremely effective yet economical solution.

As reliable as it is practical, the mechanical gate is designed to be used in areas to positively indicate the entrance / exit flow and is particularly suited to where maximum security is not required.

Perfect for heavy footfall areas like retail supermarkets & busy office buildings.

The gate is designed to open through 90 degrees and return to the closed position under spring tension. A standard feature of these gates is the ability to be opened in the reverse direction by firm body pressure to give an emergency exit facility.

A simple adjustment negates this facility when used as an exit.

## KEY PRODUCT FEATURES:

- Mechanical (non-powered assisted) Design
- Mild Steel Body in Bright Chrome
- Left or right opening options Available
- Adjustable arm opening from 650mm – 1100mm
- Suitable for Disabled Access
- 90 Degree Operation

## TECHNICAL SPECIFICATIONS:

DESCRIPTION	VALUE	UNIT OF MEASUREMENT
Dimensions Arm	1075mm x 650mm-1100mm x 182mm	H x W x D
Weight	15	KG
Passage Width	650-1100	mm
Throughput	30	Persons / min
Electrical Input	No Power Required	V

**ADDITIONAL OPTIONS:**

- This unit has additional access control mounting points if required.

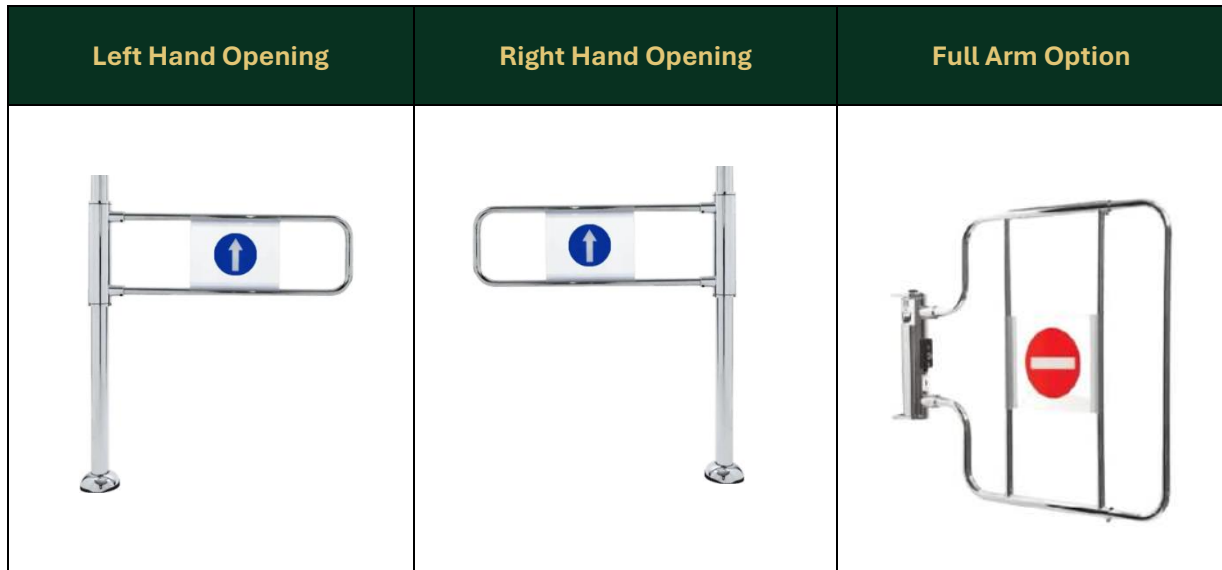

**DRAWINGS:**

Dimensions

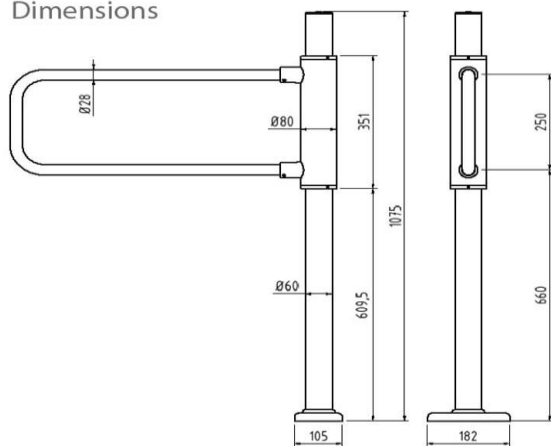

Foot prints

