

PRODUCT DATA SHEET

VERSION 1

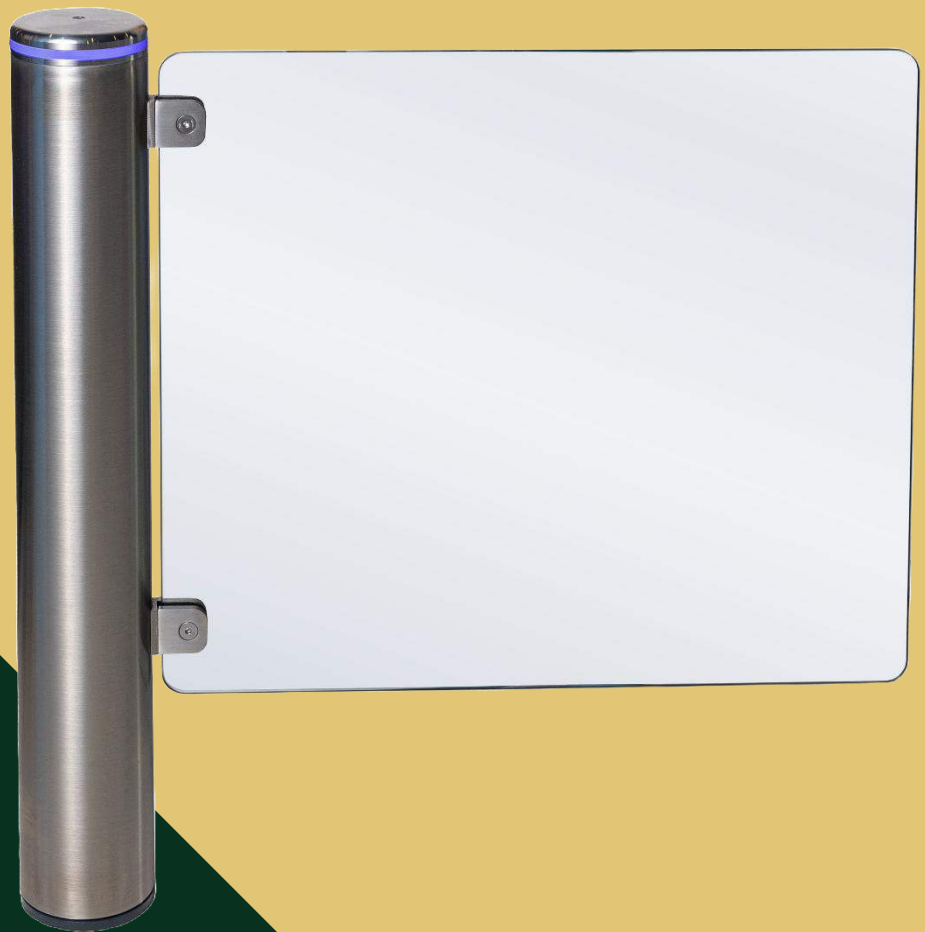

UKT-115 Fully Automatic Swing Gate

The UKT-115 is a fully automatic glass access gate that is commonly used alongside our full range of turnstiles. Its modern appearance and ergonomic design make it possible to fit the unit in any office reception lobby, gym or school environment. It is ideal for any place whenever there is a need to ensure an even distribution of people in a controlled manner.

This access gate provides ample access with its different glass panel sizes and is ideal for disabled users in wheelchairs or mobile scooters. The stainless-steel housing provides high-quality durable aesthetic looks along with the highly visible frameless design.

A simple adjustment negates this facility when used as an exit.

KEY PRODUCT FEATURES:

- Electric Motor Driven
- Stainless Steel Column
- 90° of opening from centre in both directions
- Free passage on power failure
- Automatic 'emergency exit' function
- Compatible with all types of electronic access control systems
- Suitable for all types of access

TECHNICAL SPECIFICATIONS:

DESCRIPTION	VALUE	UNIT OF MEASUREMENT
Dimensions	940mm x 991mm x 182mm	H x W x D
Weight	40	KG
Passage Width	850	mm
Throughput	20	Persons / min
Electrical Input	230	V

DRAWINGS:

FRAMELESS

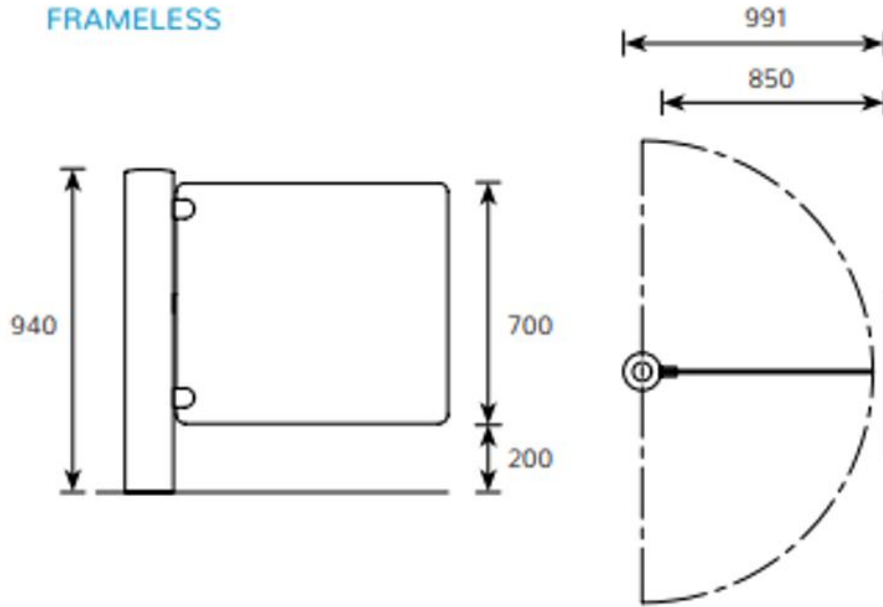

STAINLESS STEEL FRAME

